

# Robot Spider Cutting Plan

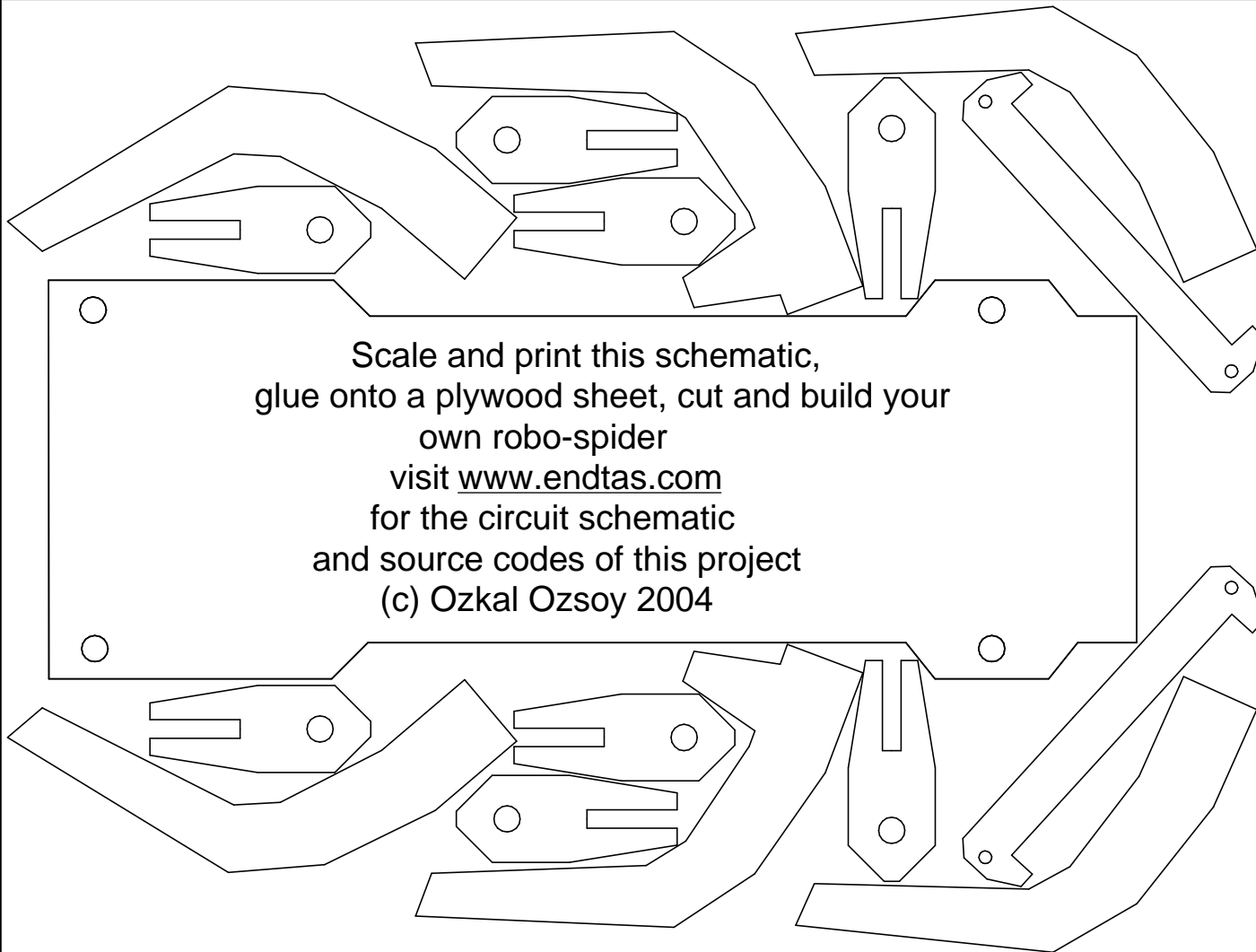

middle legs (2 total) will move up-down only,  
while the front and aft legs (4 total) will move forward-reverse.

left front and left back legs and  
right front and right back legs will move together;  
Connect them together with a suitable metal or plywood piece

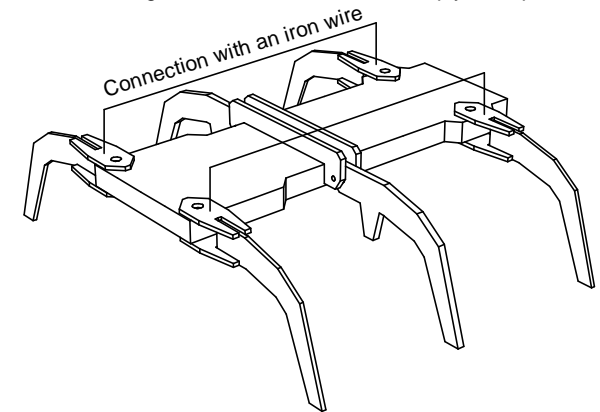

Finished spider assembly ready for the circuits' montage

While scaling the plan, consider the size of servos you'll use,

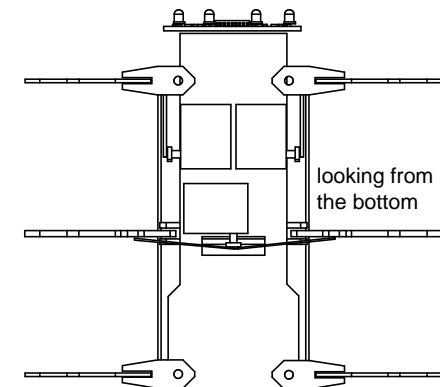

[www.endtas.com](http://www.endtas.com)  
robotics

(c) Özkal Özsoy  
2004